

HM - Wendeplatten zum Drehen

RG 16

Generell: HM Sorte NT 15/H15X - speziell für Guss und NT 25/SM 25 - universal und für Stahl

Turning inserts

TPUN

positiver Spanwinkel

Bestell-Nr.	Bezeichnung	€/ Stück	L	d	r
6 506 1013	110 208 SM 25	4,70	11,0	2,38	0,80
1855	160 304 NT 25	5,90	16,5	3,18	0,40
2055	160 308 NT 25	5,90	16,5	3,18	0,80
2855	220 408 NT 25	8,30	22,0	4,76	0,80

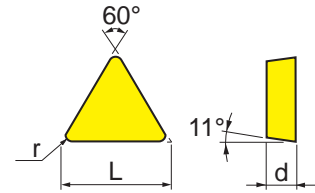

TNMG

Spanformstufen, beidseitig

Bestell-Nr.	Bezeichnung	€/ Stück	L	d	r
6 522 3061	160 404 - 13 NT 35	5,60	16,5	4,76	0,40
3261	160 408 - 13 NT 35	5,60	16,5	4,76	0,80
3461	160 412 - 13 NT 35	5,60	16,5	4,76	1,20

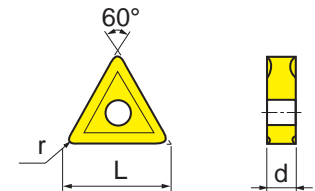

TPMR

positive Grundform

Bestell-Nr.	Bezeichnung	€/ Stück	L	d	r
6 508 1055	110 304 NT 25	5,70	11,0	3,18	0,40
1455	160 304 NT 25	6,20	16,5	3,18	0,40
1655	160 308 NT 25	6,20	16,5	3,18	0,80

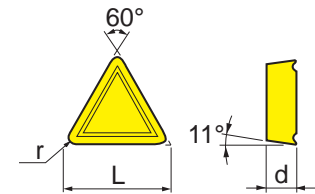

CNMG

negative Grundform

Bestell-Nr.	Bezeichnung	€/ Stück	L	d	r
6 538 2255	120 408 - 13 NT 25	6,40	12,9	4,76	0,80

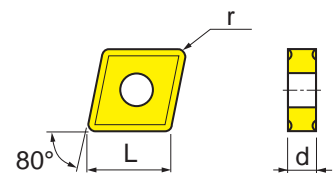

CCMT

Bestell-Nr.	Bezeichnung	€/ Stück	L	d	r
6 579 0654	060 202 NT 25	6,50	6,5	2,38	0,20
0655	060 204 NT 25	6,50	6,5	2,38	0,40
1055	09T 304 NT 25	7,60	9,7	3,97	0,40
1069	09T 304 NT 15	7,60	9,7	3,97	0,40
1070	09T 308 NT 25	7,60	9,7	3,97	0,80

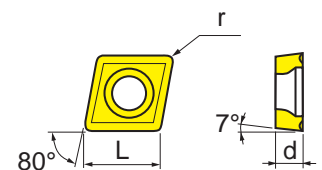

4

HM - Wendepplatten zum Drehen

RG 16

Turning inserts

SNMG

Spanform, beidseitig

Bestell-Nr.	Bezeichnung	€/ Stück	L	d	r
6 530 2255	120 404 - 13 NT 25	6,40	12,7	4,76	0,40
2455	120 408 - 13 NT 25	6,40	12,7	4,76	0,80

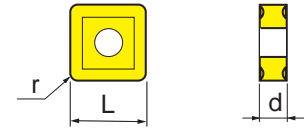

DNMG

negative Grundform

Bestell-Nr.	Bezeichnung	€/ Stück	L	d	r
6 540 1255	150 608 - 15 NT 25	8,95	15,5	4,76	0,80

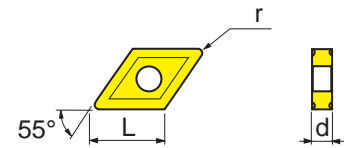

DCMT

Bestell-Nr.	Bezeichnung	€/ Stück	L	d	r
6 580 1255	070 204 NT 25	7,50	7,8	2,38	0,40
1855	11T 304 NT 25	8,30	11,6	2,38	0,40

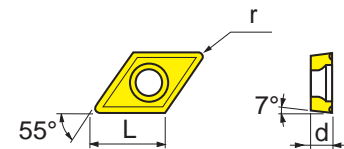

WCMT

Bestell-Nr.	Bezeichnung	€/ Stück	L	d	r
6 586 1461	06T 308 NT 35	8,80	6,5	3,97	0,80

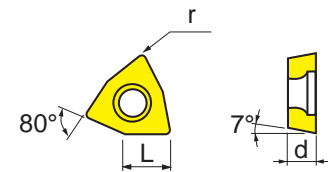

HM - Wendepplatten zum Stechen

RG 16

Inserts for parting off

LFMX

Bestell-Nr.	Bezeichnung	€/ Stück	L	W
6 585 1012	LFMX 2N SM 25	5,80	9,3	2,2
1013	LFMX 3N SM 25	5,80	11,3	3,1
1213	LFMX 4N SM 25	7,30	11,3	4,1

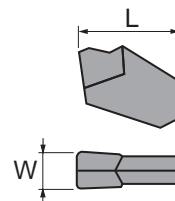

150.15

Bestell-Nr.	Bezeichnung	€/ Stück	L	W
6 587 1013	150.15 - 9030 SM 25	8,40	9,0	3,0
1213	150.15 - 9040 SM 25	9,05	9,0	4,0

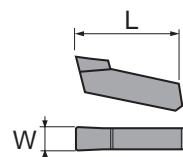

HM - Wendeplatten zum Fräsen

RG 16

Milling inserts

TPKN

positiver Spanwinkel

Bestell-Nr.	Bezeichnung	€/ Stück	L	d
6 554 1013	1603 PP-R SM 25	5,50	16,5	3,18
1041	1603 PP-R H 15X	5,50	16,5	3,18
1413	2204 PP-R SM 25	7,70	22,0	4,76
1441	2204 PP-R H 15X	7,70	22,0	4,76

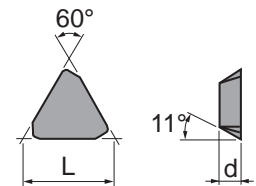

SEKN

positiver Spanwinkel

Bestell-Nr.	Bezeichnung	€/ Stück	L	d
6 567 1013	1203 AFTN SM 25	9,00	12,7	3,18
1213	1203 AFN SM 25	6,80	12,7	3,18

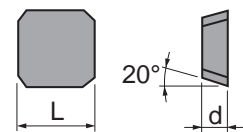

AFTN - Für Guss und Schruppbearbeitung von Stahl
AFN - Für Schlichtbearbeitung und weichere Materialien

SPKN

positiver Spanwinkel

Bestell-Nr.	Bezeichnung	€/ Stück	L	d
6 558 1013	1203 ED-R SM 25	6,50	12,7	3,18
1041	1203 ED-R H 15X	6,50	12,7	3,18

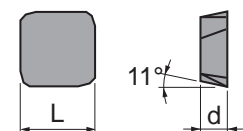

! Ausführungen der Spanbrecher sind optimiert für die jeweilige Materialsorte und können von der Abbildung abweichen !

4

HM - Wendepplatten zum Gewindedrehen RG 16

Inserts for thread cutting

166.1R

Bestell-Nr.	Bezeichnung	€/ Stück	D	d	Steigung
6 589 1007	166.1R - 100 S 10 S	8,70	9,52	3,18	1,0 - 60°
1207	166.1R - 150 S 10 S	8,70	9,52	3,18	1,5 - 60°
1407	166.1R - 200 S 10 S	8,70	9,52	3,18	2,0 - 60°
1607	166.1R - 300 S 10 S	9,90	9,52	3,18	3,0 - 60°

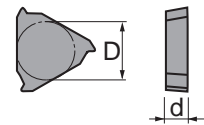

ER

Bestell-Nr.	Bezeichnung	€/ Stück	D	d	Steigung
6 590 1010	16ER - 05 - 15 M	14,70	9,52	3,60	0,5 - 1,5 - 60°
1030	16ER - 15 - 30 M	14,70	9,52	3,60	1,5 - 3,0 - 60°
1050	16ER - 08 - 14 W	14,70	9,52	3,60	8,0 - 14,0 - 55°
1070	16ER - 14 - 28 W	14,70	9,52	3,60	14,0 - 28,0 - 55°

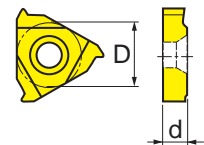

NR

Bestell-Nr.	Bezeichnung	€/ Stück	D	d	Steigung
6 590 2010	11NR - 05 - 15 M	14,70	6,35	3,18	0,5 - 1,5 - 60°
2030	16NR - 05 - 15 M	14,70	9,52	3,60	0,5 - 1,5 - 60°
2040	16NR - 15 - 30 M	14,70	9,52	3,60	1,5 - 3,0 - 60°
2045	11NR - 16 - 48 W	14,70	6,35	3,18	16,0 - 48,0 - 55°
2050	16NR - 08 - 14 W	14,70	9,52	3,60	8,0 - 14,0 - 55°
2060	16NR - 14 - 28 W	14,70	9,52	3,60	14,0 - 28,0 - 55°

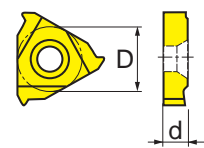

Klemmhalter

RG 34

PTGNR / 117.26 / 90°

System P



Toolholders for turning

Bestell-Nr.	Halter	€/ Stück	H	B	L	F	E	Wendepatte
6 601 0202	PTGNR 2020 - 16	61,40	20	20	125	25	24	TNMG 1604rr
0252	PTGNR 2525 - 16	69,20	25	25	150	32	24	TNMG 1604rr
0322	PTGNR 3225 - 16	76,10	32	25	170	32	24	TNMG 1604rr

Ersatzteile: (Preise siehe Ersatzteilpreisliste auf Seite 98)	Auflageplatte	Pin	Spannplatte R	Spannschraube	Sechskantschlüssel	Ausschlagdorn
PTGNR 2020 - 16	117.26 - 622	117.26 - 650.1	110.26 - 641	117.26 - 655	3 SMS 795	117.26 - 686
PTGNR 2525 - 16	117.26 - 622	117.26 - 650.1	110.26 - 641	117.26 - 655	3 SMS 795	117.26 - 686
PTGNR 3225 - 16	117.26 - 622	117.26 - 650.1	110.26 - 641	117.26 - 655	3 SMS 795	117.26 - 686

Klemmhalter

RG 34

PSSNR / 111.26 / 45°

System P



Toolholders for turning

Bestell-Nr.	Halter	€/ Stück	H	B	L	F	E	Wendepatte
6 607 0202	PSSNR 2020 - 12	61,40	20	20	125	25	28	SNMG 1204rr
0252	PSSNR 2525 - 12	69,20	25	25	150	32	28	SNMG 1204rr
0322	PSSNR 3225 - 12	76,10	32	25	170	32	28	SNMG 1204rr

Ersatzteile: (Preise siehe Ersatzteilpreisliste auf Seite 98)	Auflageplatte	Pin	Spannplatte R	Spannschraube	Sechskantschlüssel	Ausschlagdorn
PSSNR 2020 - 12	111.26 - 622	117.26-650.1	110.26 - 640	117.26 - 655	3 SMS 795	117.26 - 686
PSSNR 2525 - 12	111.26 - 622	117.26-650.1	110.26 - 640	117.26 - 655	3 SMS 795	117.26 - 686
PSSNR 3232 - 12	111.26 - 622	117.26-650.1	110.26 - 640	117.26 - 655	3 SMS 795	117.26 - 686

4

Klemmhalter

RG 34

PCLNR / 123.26 / 95°

System P

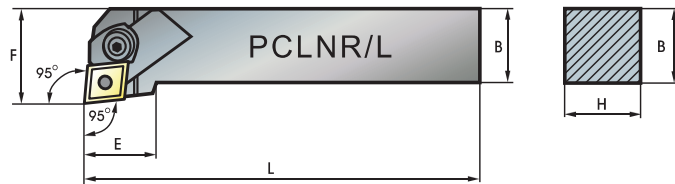

Toolholders for turning

Bestell-Nr.	Halter	€/ Stück	H	B	L	F	E	Wendepatte
6 609 0202	PCLNR 2020 - 12	61,40	20	20	125	25	18	CNMG 1204rr
0252	PCLNR 2525 - 12	69,20	25	25	150	32	18	CNMG 1204rr
0322	PCLNR 3225 - 12	76,10	32	25	170	32	18	CNMG 1204rr

Ersatzteile: (Preise siehe Ersatzteilpreisliste auf Seite 98)	Auflageplatte	Pin	Spannplatte R	Spann- schraube	Sechskant- schlüssel	Ausschlag- dorn
PCLNR 2020 - 12	123.26 - 622	170.26 - 650.1	110.26 - 640	117.26 - 655	3 SMS 795	117.26 - 686
PCLNR 2525 - 12	123.26 - 622	170.26 - 650.1	110.26 - 640	117.26 - 655	3 SMS 795	117.26 - 686
PCLNR 3225 - 12	123.26 - 622	170.26 - 650.1	110.26 - 640	117.26 - 655	3 SMS 795	117.26 - 686

Klemmhalter

RG 34

PDJNR / L 93°

System P



Toolholders for turning

Bestell-Nr.	Halter	€/ Stück	H	B	L	F	E	Wendepatte
Rechts								
6 611 0202	PDJNR 2020 - 15	61,40	20	20	125	25	40	DNMG 1506rr
0252	PDJNR 2525 - 15	69,20	25	25	150	32	40	DNMG 1506rr
0322	PDJNR 3225 - 15	76,10	32	25	170	32	40	DNMG 1506rr
Links								
6 611 1202	PDJNL 2020 - 15	61,40	20	20	125	25	40	DNMG 1506rr
1252	PDJNL 2525 - 15	69,20	25	25	150	32	40	DNMG 1506rr
1322	PDJNL 3225 - 15	76,10	32	25	170	32	40	DNMG 1506rr

Ersatzteile: (Preise siehe Ersatzteilpreisliste auf Seite 98)	Auflageplatte	Pin	Spannplatte	Spann- schraube	Sechskant- schlüssel	Ausschlag- dorn
PDJNR / L 2020 - 15	171.66 - 624	171.66 - 650.1	171.66 - 660	117.26 - 655	3 SMS 795	117.26 - 686
PDJNR / L 2525 - 15	171.66 - 624	171.66 - 650.1	171.66 - 660	117.26 - 655	3 SMS 795	117.26 - 686
PDJNR / L 3225 - 15	171.66 - 624	171.66 - 650.1	171.66 - 660	117.26 - 655	3 SMS 795	117.26 - 686

Klemmhalter

RG 34







PDNNN 63°

System P



Toolholders for turning

Bestell-Nr.	Halter	€/ Stück	H	B	L	F	E	Wendeplatte
6 601 1252	PDNNN 2525 - 15	69,20	25	25	150	12,5	45	DNMG 1506rr
2322	PDNNN 3225 - 15	76,10	32	25	170	12,5	45	DNMG 1506rr

Ersatzteile: (Preise siehe Ersatzteilliste auf Seite 98)	 Auflageplatte	 Pin	 Spannplatte	 Spannschraube	 Sechskantschlüssel	 Ausschlagdorn
PDNNN 2525 - 15	171.66 - 624	171.66 - 650.1	171.66 - 660	117.26 - 655	3 SMS 795	117.26 - 686
PDNNN 3225 - 15	171.66 - 624	171.66 - 650.1	171.66 - 660	117.26 - 655	3 SMS 795	117.26 - 686

Klemmhalter

RG 34

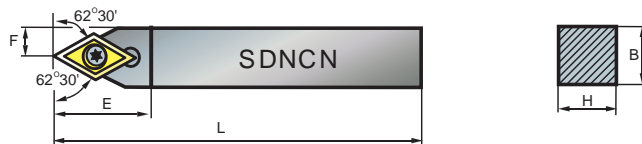

SDNCN 63°

System S



Toolholders for turning

Bestell-Nr.	Halter	€/ Stück	H	B	L	F	E	Wendeplatte
6 621 6080	SDNCN 0808 - 07	48,30	8	8	60	4	15	DCMT 070 2rr
6101	SDNCN 1010 - 07	49,40	10	10	70	5	15	DCMT 070 2rr
6121	SDNCN 1212 - 11	48,00	12	12	80	6	22	DCMT 11T 3rr
6161	SDNCN 1616 - 11	50,60	16	16	100	8	22	DCMT 11T 3rr
6201	SDNCN 2020 - 11	82,70	20	20	125	10	22	DCMT 11T 3rr
6251	SDNCN 2525 - 11	90,10	25	25	150	12,5	22	DCMT 11T 3rr

Ersatzteile: (Preise siehe Ersatzteilliste auf Seite 98)	 Spannschraube	 Schlüssel
SDNCN 0808 - 07	S - 2506	T 7
SDNCN 1010 - 07	S - 2506	T 7
SDNCN 1212 - 11	S - 4008	T 15
SDNCN 1616 - 11	S - 4008	T 15
SDNCN 2020 - 11	S - 4008	T 15
SDNCN 2525 - 11	S - 4008	T 15

4

Klemmhalter

RG 34



SCLCR 95°

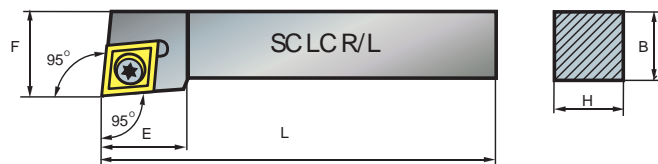

System S



Toolholders for turning

Bestell-Nr.	Halter	€/ Stück	H	B	L	F	E	Wendepatte
6 620 0081	SCLCR 0808 - 06	48,30	8	8	60	10	10	CCMT 060 2rr
0101	SCLCR 1010 - 06	49,40	10	10	70	12	10	CCMT 060 2rr
0121	SCLCR 1212 - 09	48,00	12	12	80	16	14	CCMT 09T 3rr
0161	SCLCR 1616 - 09	50,60	16	16	100	20	14	CCMT 09T 3rr

Ersatzteile: (Preise siehe Ersatzteilpreisliste auf Seite 98)	 Spannschraube	 Schlüssel Winkel m. Fahne	
		Winkel	m. Fahne
SCLCR 0808 - 06	S - 2506	T 7	T 7 - F
SCLCR 1010 - 06	S - 2506	T 7	T 7 - F

Ersatzteile: (Preise siehe Ersatzteilpreisliste auf Seite 98)	 Spannschraube	 Schlüssel Winkel m. Fahne	
		Winkel	m. Fahne
SCLCR 1212 - 09	S - 4008	T 15	T 15 - F
SCLCR 1616 - 09	S - 4008	T 15	T 15 - F

Klemmhalter

RG 34



SDJCR / L 93°



System S



Toolholders for turning

Bestell-Nr.	Halter	€/ Stück	H	B	L	F	E	Wendepatte
Rechts								
6 621 5080	SDJCR 0808 - 07	48,30	8	8	60	10	16	DCMT 070 2rr
5101	SDJCR 1010 - 07	49,40	10	10	70	12	16	DCMT 070 2rr
5121	SDJCR 1212 - 11	48,00	12	12	80	16	20	DCMT 11T 3rr
5161	SDJCR 1616 - 11	50,60	16	16	100	20	20	DCMT 11T 3rr
Links								
6 620 1080	SDJCL 0808 - 07	48,30	8	8	60	10	16	DCMT 070 2rr
1101	SDJCL 1010 - 07	49,40	10	10	70	12	16	DCMT 070 2rr
1121	SDJCL 1212 - 11	48,00	12	12	80	16	20	DCMT 11T 3rr
1161	SDJCL 1616 - 11	50,60	16	16	100	20	20	DCMT 11T 3rr

Ersatzteile: (Preise siehe Ersatzteilpreisliste auf Seite 98)	 Spannschraube	 Schlüssel Winkel m. Fahne	
		Winkel	m. Fahne
SDJCR / L 0808 - 07	S - 2506	T 7	T 7 - F
SDJCR / L 1010 - 07	S - 2506	T 7	T 7 - F

Ersatzteile: (Preise siehe Ersatzteilpreisliste auf Seite 98)	 Spannschraube	 Schlüssel Winkel m. Fahne	
		Winkel	m. Fahne
SDJCR / L 1212 - 11	S - 4008	T 15	T 15 - F
SDJCR / L 1616 - 11	S - 4008	T 15	T 15 - F

Klemmhalter

RG 34

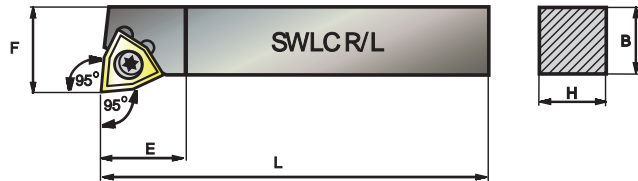

SWLCR 95°

System S



Toolholders for turning

Bestell-Nr.	Halter	€/ Stück	H	B	L	F	E	Wendepatte
6 623 1121	SWLCR 1212-06	48,00	12	12	80	16	13	WCMT 06T 308
1161	SWLCR 1616-06	50,60	16	16	100	20	13	WCMT 06T 308

Ersatzteile: (Preise siehe Ersatzteilpreisliste auf Seite 98)		
SWLCR 1212-06	S - 4008	T 15
SWLCR 1616-06	S - 4008	T 15

Klemmhalter

RG 34



S...-SCLCR 95°

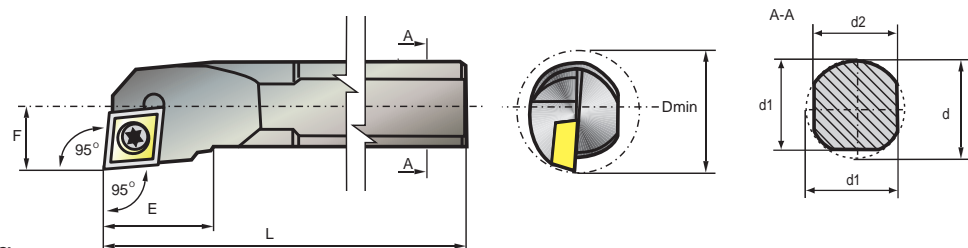

System S



Toolholders for boring

Bestell-Nr.	Halter	€/ Stück	d	L	F	d1	d2	D min	E	Wendepatte
6 622 0080	S 08 H SCLCR-06	70,20	8	100	4,5	7,5	7,0	9	13	CCMT 060 2rr
0100	S 10 K SCLCR-06	68,90	10	125	7,0	9,3	8,5	13	12	CCMT 060 2rr
0120	S 12 M SCLCR-09	55,50	12	150	9,0	11,0	10,0	17	19	CCMT 09T 3rr
0160	S 16 R SCLCR-09	69,00	16	200	11,0	15,0	13,5	22	19	CCMT 09T 3rr
0200	S 20 S SCLCR-09	79,10	20	250	13,0	19,0	17,5	25	15	CCMT 09T 3rr

Ersatzteile: (Preise siehe Ersatzteilpreisliste auf Seite 98)		
S...-SCLCR S 08 H	S - 2504	T 7
S...-SCLCR S 10 K	S - 2506	T 7
S...-SCLCR S 12 M	S - 4008	T 15

Ersatzteile: (Preise siehe Ersatzteilpreisliste auf Seite 98)		
S...-SCLCR S 16 R	S - 4008	T 15
S...-SCLCR S 20 S	S - 4008	T 15

4

Klemmhalter mit Innenkühlung

RG 34

A...-SCLCR 95°

System S

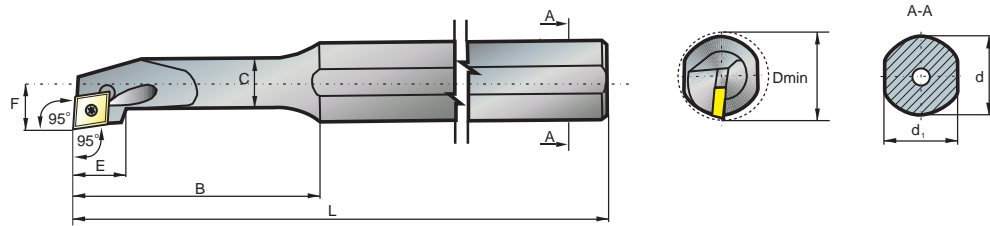

Toolholders for boring with internal cooling

Bestell-Nr.	Halter	€/ Stück	D min	d	L	B	F	E	C	d1	Wendepatte
6 622 1100	A 0810 J SCLCR-06	92,20	11	10	110	32	6	10,5	8	9	CCMT 060 2rr
1120	A 1012 K SCLCR-06	100,60	13	12	125	38	7	11,5	10	11	CCMT 060 2rr
1160	A 1216 M SCLCR-06	109,80	17	16	150	50	9	10,0	12	15	CCMT 060 2rr

Ersatzteile:
(Preise siehe
Ersatzteilpreisliste
auf Seite 98)



Spann-
schraube



Schlüssel

A 0810 J SCLCR-06

S - 2506

T 7

A 1012 K SCLCR-06

S - 2506

T 7

A 1216 M SCLCR-06

S - 2506

T 7

Klemmhalter mit Innenkühlung

RG 34

A...-SCLCR 95°

System S

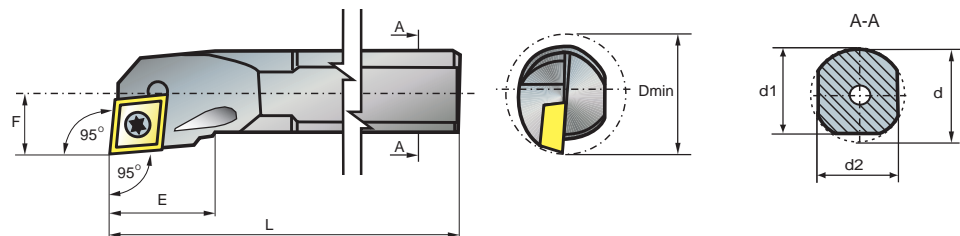

Toolholders for boring with internal cooling

Bestell-Nr.	Halter	€/ Stück	D min	d	L	F	E	d1	d2	Wendepatte
6 622 2120	A 12 M SCLCR-09	93,50	17	12	150	9	19	11	10,0	CCMT 09T 3rr
2160	A 16 R SCLCR-09	102,20	22	16	150	11	19	15	13,5	CCMT 09T 3rr
2200	A 20 S SCLCR-09	111,50	25	20	180	13	15	19	17,5	CCMT 09T 3rr

Ersatzteile:
(Preise siehe
Ersatzteilpreisliste
auf Seite 98)



Spann-
schraube



Schlüssel

A 12 M SCLCR-09

S - 4008

T 15

A 16 R SCLCR-09

S - 4008

T 15

A 20 S SCLCR-09

S - 4008

T 15

Klemmhalter

RG 34 S...-CTFPR / 136.17 / 92°

System C

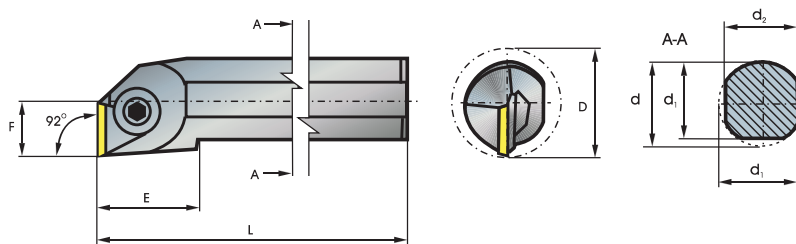

Toolholders for turning

Bestell-Nr.	Halter	€/ Stück	d	D min	L	F	E	d1	d2	Wendeplatte
6 630 2160	S 16 R CTFPR - 11	71,70	16	21	200	11	19	15	13,5	TPUN 1102rr
2200	S 20 S CTFPR - 16	100,60	20	20	250	13	26	19	17,5	TPUN 1603rr
2250	S 25 T CTFPR - 16	120,40	25	25	300	17	31	24	22,5	TPUN 1603rr

Ersatzteile: (Preise siehe Ersatzteilliste auf Seite 98)	 Spann- brechersatz	 Spann- schraube R	 Sechskant- schlüssel
S...-CTFPR S 16 R - 11	117.16-630	174.16-639	3 SMS 795
S...-CTFPR S 20 S - 16	117.16-630	174.16-639	3 SMS 795
S...-CTFPR S 25 T - 16	117.16-631	174.16-645	4 SMS 795

Klemmhalter zum Gewindedrehen

RG 34

166.1R

Für Aussengewinde
System C

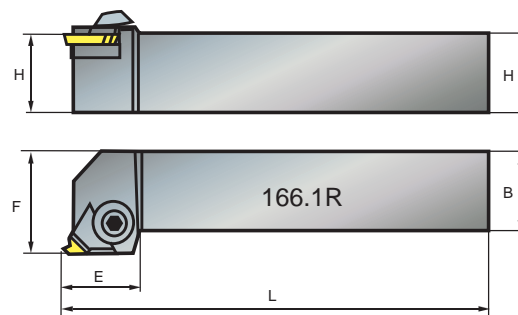

Toolholders for outside thread cutting

Bestell-Nr.	Halter	€/ Stück	H	B	L	F	E	Wendeplatte
6 635 2161	166.1 R 1616	87,70	16	16	100	20	20	166.1 R - rr
2202	166.1 R 2020	91,40	20	20	125	25	20	166.1 R - rr
2252	166.1 R 2525	107,10	25	25	150	32	20	166.1 R - rr

Ersatzteile: (Preise siehe Ersatzteilliste auf Seite 98)	Gewinde- steigung	 Auflage- platte	 Schraube für Auflageplatte	 Spann- brechersatz	 Spann- schraube	 Sechskant- schlüssel
166.1 R 1616	0,5 - 1,25	R166.10-621.1	174.10-650	PTF 11	174.16-644	2 SMS 795 / 4 SMS 795
166.1 R 2020	1,5 - 2,00	R166.10-621.2	174.10-650	PTF 12	174.16-644	2 SMS 795 / 4 SMS 795
166.1 R 2525	2,5 - 3,00	R166.10-621.3	174.10-650	PTF 13	174.16-644	2 SMS 795 / 4 SMS 795

4

Klemmhalter zum Gewindedrehen

RG 34

PER

Für Aussengewinde
System P

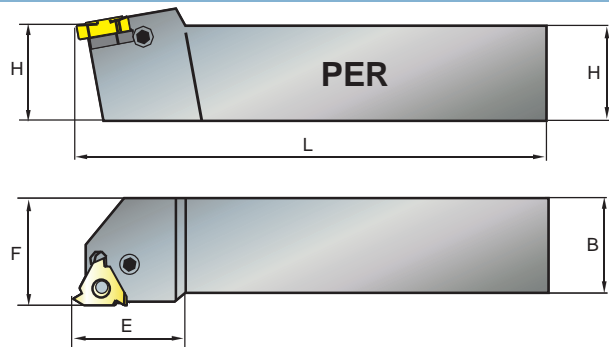

Toolholders for outside thread cutting

Bestell-Nr.	Halter	€/Stück	H	B	L	F	E	Wendeplatte für alle Typen verwendbar
6 636 0161	PER 1616H - 16K	110,10	16	16	100	20	23	16ER-0,5-15M 16ER-1,5-30M 16ER-14-28W 16ER-08-14W
0202	PER 2020K - 16K	116,90	20	20	125	25	23	
0252	PER 2525M - 16K	123,10	25	25	150	25	-	

Ersatzteile: (Preise siehe Ersatzteilpreisliste auf Seite 98)	Auflageplatte	Schraube für Auflageplatte	Kniehebel	Spann- schraube	Sechskant- schlüssel
PER 1616H - 16K	GP-16.01	GS-R3.06	KK-090.10	KS-060.16	3 SMS 795
PER 2020K - 16K	GP-16.01	GS-R3.06	KK-090.10	KS-060.16	3 SMS 795
PER 2525M - 16K	GP-16.01	GS-R3.06	KK-090.10	KS-060.16	3 SMS 795

Klemmhalter zum Gewindedrehen

RG 34

SIR

Für Innengewinde
System S

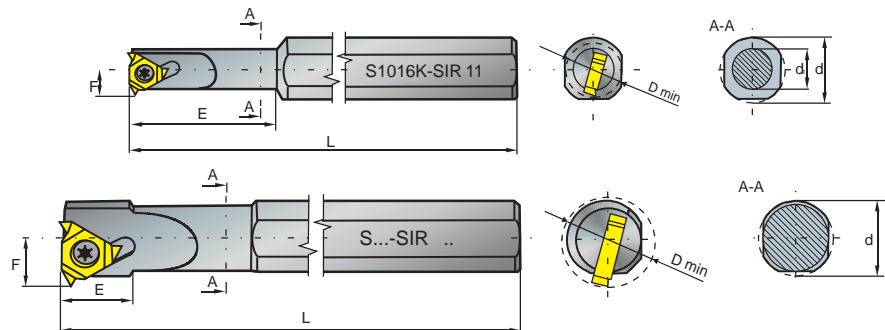

Toolholders for inside
thread cutting

Bestell-Nr.	Halter	€/Stück	D min	d	L	F	E	d1
6 636 1101	S 1016 M - SIR 11	73,50	12	16	150	7	30	10
1102	S 10 K - SIR 11	63,40	12	10	125	7	8	
1120	S 12 M - SIR 11	66,80	14	12	150	7,5	8	
1160	S 16 M - SIR 16	75,40	20	16	150	10	15	
1200	S 20 Q - SIR 16	92,30	24	20	180	12	16	

Ersatzteile: (Preise siehe Ersatzteilpreisliste auf Seite 98)	Spann- schraube	Sechskant- schlüssel	Wendeplatte	
S 1016 M - SIR 11	S - 2506	T 7	11NR-05-15M	11NR-16-48W
S 10 K - SIR 11	S - 2506	T 7		
S 12 M - SIR 11	S - 2506	T 7		
S 16 M - SIR 16	S - 3509	T 15	16NR-05-15M / 16NR-1,5-30M	
S 20 Q - SIR 16	S - 3509	T 15	16NR-14-28W / 16NR-08-14W	

Klemmhalter zum Stechdrehen

RG 34

150.17R

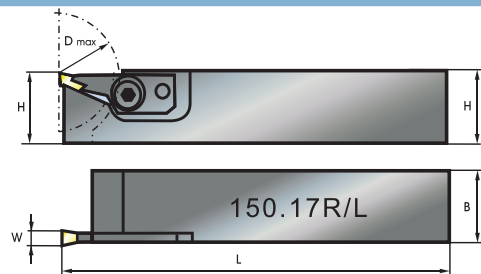

Toolholders for parting

Bestell-Nr.	Halter	€/ Stück	H	B	W	L	D max	Wendeplatte
6 637 2203	150.17R 2020 - 3	104,90	20	20	3	125	32	150.15 - 9030
2254	150.17R 2525 - 4	127,20	25	25	4	150	40	150.15 - 9040

Ersatzteile: (Preise siehe Ersatzteilliste auf Seite 98)	Spann- platte	Spann- schraube	Sechskant- schlüssel
150.17R 2020 - 03	150.17-643	150.17-656	3 SMS 795
150.17R 2020 - 04	150.17-644	150.17-656	3 SMS 795

Grund- & Schneidhalter

RG 34

PTNn & 150.19 R

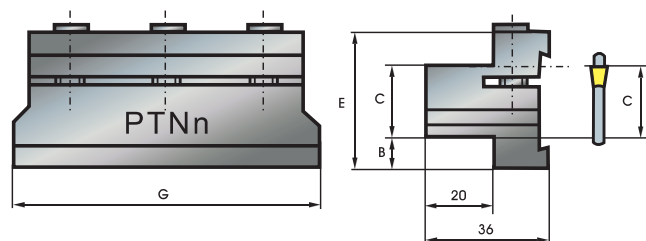

Toolholders for parting

Bestell-Nr.	Grundhalter	€/ Stück	B	C	E	G
6 638 0020	PTNn 20	126,80	8	20	38	90

Bestell-Nr.	Schneidhalter	€/ Stück	W	H	H1	A	L	D max	Wendeplatte
6 638 0202	150.19 - 20 - 2	86,80	2,1	26	19,8	1,65	110	50	LFMX 2N
0203	150.19 - 20 - 3	75,50	3,1	26	21,1	2,3	110	75	LFMX 3N
0204	150.19 - 20 - 4	82,10	4,1	26	21,0	3,2	110	80	LFMX 4N

Ersatzteile: (Preise siehe Ersatzteilliste auf Seite 98)	Spann- schraube	Sechskant- schlüssel
PTNn 20	P - 368.02	5 SMS 795
150.19 - 20 - 2	-	-
150.19 - 20 - 3	-	-
150.19 - 20 - 4	-	-

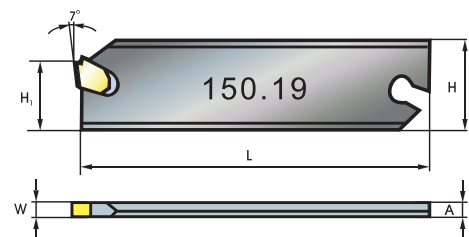

4

Schafffräser mit Zylinderschaft

RG 45

R 215.17

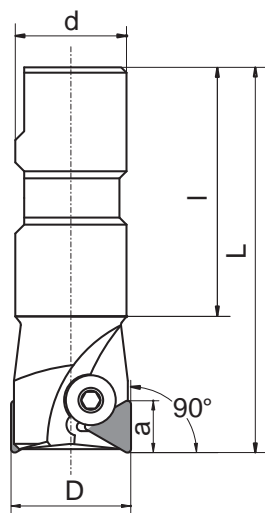

Einstellwinkel 90°, wird in Rechtsausführung (R) hergestellt

Schneidewinkel: Spanwinkel 0°
 Axialwinkel 0°
 Radialwinkel 0°



End mill with flattened shank

Bestell-Nr.	Durchmesser	€/ Stück	D	d	L	l	a	Z	Wendeplatte
6 650 0112	215.17 - 1212.3	69,00	12	12	70	45	11	1	TPKN 110 2rr
0116	215.17 - 1616.3	72,00	16	16	75	48	11	1	TPKN 110 2rr
0120	215.17 - 2020.3	95,00	20	20	82	50	11	2	TPKN 110 2rr

Ersatzteile: (Preise siehe Ersatzteilpreisliste auf Seite 98)	 Spannschraube	 Sechskant- schlüssel
215.17 - 1212.3	M4 Je-410040	3 SMS 795
215.17 - 1616.3	174.16 - 636	3 SMS 795
215.17 - 2020.3	174.16 - 636	3 SMS 795

4

Eckfräser

RG 45

220.17

Einstellwinkel 90°, wird in Rechtsausführung (R) hergestellt

Schneidewinkel: Spanwinkel 0°
 Axialwinkel 0°
 Radialwinkel 0°

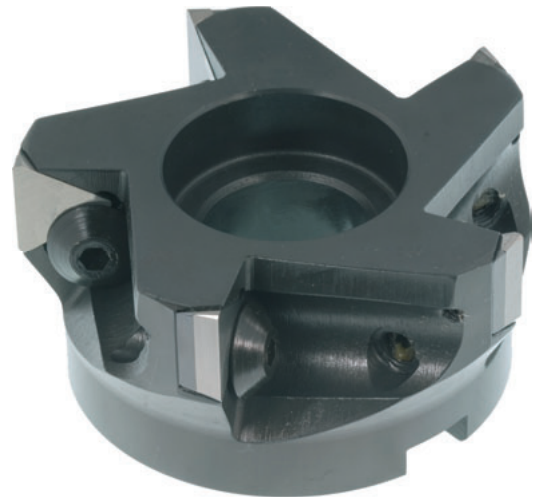
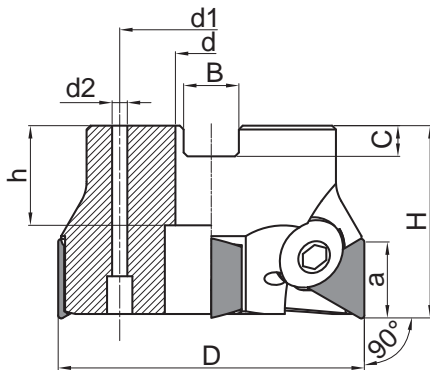

4

Besonderheit:

Ungleichmäßige Teilung → verhindert Rattern

Sqare milling cutter

Bestell-Nr.	Durchmesser	€/ Stück	D	d	d1	d2	H	h	B	a	C	Z	Wendeplatte
6 655 1040	220.17 - 40	128,50	40	16	-	-	40	20	8,4	16,5	5,6	3	TPKN 160 3rr
1050	220.17 - 50	134,40	50	22	-	-	40	20	10,4	16,5	6,3	3	TPKN 160 3rr
1063	220.17 - 63	170,70	63	22	-	-	47	20	10,4	22,0	6,3	3	TPKN 220 4rr
1080	220.17 - 80	242,40	80	27	-	-	50	22	12,4	22,0	7,0	4	TPKN 220 4rr
1100	220.17 - 100	305,40	100	32	-	-	50	32	14,4	22,0	8,0	5	TPKN 220 4rr
1125	220.17 - 125	389,10	125	40	-	-	63	35	16,4	22,0	9,0	6	TPKN 220 4rr
1160	220.17 - 160	471,30	160	40	66,7	14	63	29	16,4	22,0	9,0	7	TPKN 220 4rr
1200	220.17 - 200	653,80	200	60	101,6	18	63	40	25,7	22,0	14,0	8	TPKN 220 4rr

Ersatzteile: (Preise siehe Ersatzteipreisliste auf Seite 98)	Aufspannung					
	Spannschraube	Auflage- platte	Schraube für Auflageplatte	Sechskant- schlüssel	Schraube f. Fräsdorn	Sechskant- schlüssel
220.17 - 40	174.16 - 644	-	-	4	220.17 - 690	5 SMS 795
220.17 - 50	174.16 - 644	-	-	4	220.17 - 691	6 SMS 795
220.17 - 63	174.16 - 648	-	-	5	220.17 - 692	8 SMS 795
220.17 - 80	174.16 - 648	175.11 - 624	174.10 - 650	5+2	M12 x 35	10 SMS 795
220.17 - 100	174.16 - 648	175.11 - 624	174.10 - 650	5+2	-	-
220.17 - 125	174.16 - 648	175.11 - 624	174.10 - 650	5+2	-	-
220.17 - 160	174.16 - 648	175.11 - 624	174.10 - 650	5+2	-	-
220.17 - 200	174.16 - 648	175.11 - 624	174.10 - 650	5+2	-	-

Planfräser

RG 45

R 220.27

Einstellwinkel 75°, wird in Rechtsausführung (R) hergestellt

Schneidewinkel: Spanwinkel 1°
 Axialwinkel 4°
 Radialwinkel 0°

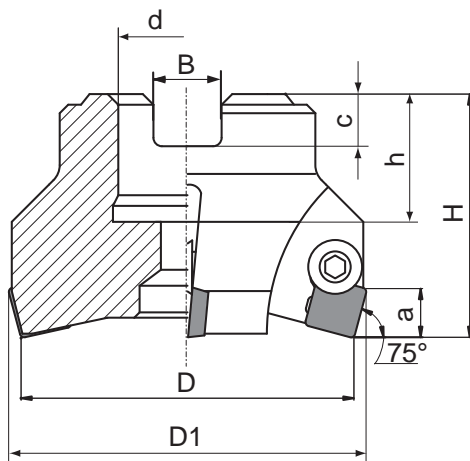

Besonderheit:
 Ungleichmäßige Teilung → verhindert Rattern

Face milling cutter

Bestell-Nr.	Durchmesser	€/ Stück	D	D1	d	B	H	h	c	a	Z	Wendepatte
6 656 1050	220.27 - 050	146,50	50	56	22	10,4	40	20	6,3	9	3	SPKN 1203 EDR
1063	220.27 - 063	177,40	63	69	22	10,4	40	20	6,3	9	4	SPKN 1203 EDR
1080	220.27 - 080	242,10	80	86	27	12,4	50	22	7,0	9	5	SPKN 1203 EDR

Ersatzteile: (Preise siehe Ersatzteilliste auf Seite 98)	Spanschraube	Schraube f. Fräsdorn	Sechskant- schlüssel
220.27 - 050	174.16 - 644	220.17 - 691	4 SMS 795 / 6 SMS 795
220.27 - 063	174.16 - 644	220.17 - 691	4 SMS 795 / 6 SMS 795
220.27 - 080	174.16 - 644	M12 x 30	4 SMS 795 / 10 SMS 795

Planfräser

RG 45

R 220.130

Einstellwinkel 45°, wird in Rechtsausführung (R) hergestellt

Schneidewinkel: Spanwinkel 6°
 Axialwinkel 20°
 Radialwinkel - 9°

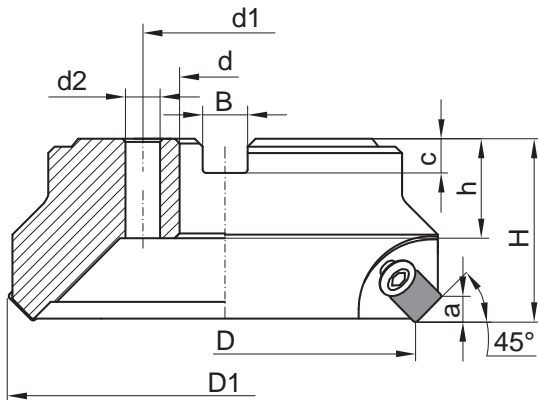





Besonderheit:

Ungleichmäßige Teilung → verhindert Rattern

Face milling cutter

Bestell-Nr.	Durchmesser	€/ Stück	D	D1	d	H	h	B	C	a	Z	Wendepatte
6 663 0401	220.130 - 40.1	200,20	40	54	22	53	20	10,4	6,3	6	3	SEKN 1203 AFTN
0501	220.130 - 50.1	236,80	50	62	22	48	20	10,4	6,3	6	4	SEKN 1203 AFTN
0631	220.130 - 63.1	261,00	63	77	22	40	20	10,4	6,3	6	5	SEKN 1203 AFTN

Ersatzteile: (Preise siehe Ersatzteilpreislite auf Seite 98)	 Spannschraube	 Schlüssel	 Schraube	 Schlüssel
220.130 - 40.1	M6 x 0,75L - Je 410790	6 SMS 795	M10 x 45 - Je - 410724	257.9 - 150
220.130 - 50.1	M8L - Je 410671	6 SMS 795	220.17-691	257.9 - 150
220.130 - 63.1	M8L - Je 410671	6 SMS 795	220.17-691	257.9 - 150

4

Planfräser

RG 45

R 220.130

Einstellwinkel 45°, wird in Rechtsausführung (R) hergestellt

Schneidewinkel: Spanwinkel 6°
 Axialwinkel 20°
 Radialwinkel -9°

Fortsetzung

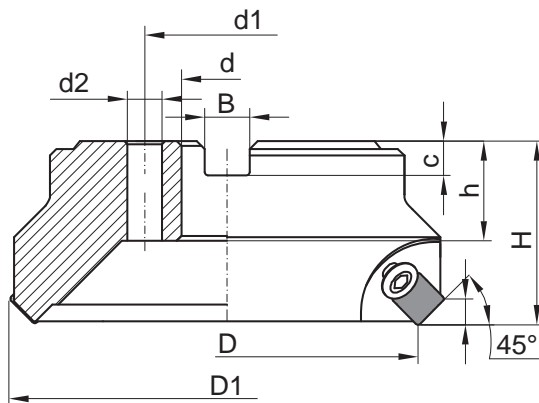

Besonderheit:
 Ungleichmäßige Teilung → verhindert Rattern

Face milling cutter

Bestell-Nr.	Durchmesser	€/ Stück	D	D1	d	d1	d2	H	h	B	C	a	Z
6 664 0080	220.130 - 80	342,90	80	94	27	-	-	50	22	12,4	7	6	6
0100	220.130 - 100	409,70	100	114	32	-	-	50	25	14,4	8	6	6
0125	220.130 - 125	455,70	125	139	40	-	-	63	28	16,4	9	6	7
0160	220.130 - 160	516,90	160	174	40	66,7	14	63	32	16,4	9	6	7
0200	220.130 - 200	733,10	200	214	60	101,6	18	63	32	25,7	14	6	8

Ersatzteile: (Preise siehe Ersatzteilpreislite auf Seite 98)	Auflageplatte	Schraube für Auflegeplatte	Spann- schraube	Sechskant- schlüssel	Schlüssel	Wendeplatte
220.130 - 80	220.13 - 621-12	174.10 - 650	M8L Je-410671	2 SMS 795	257.9 - 150	SEKN 1203 AFTN
220.130 - 100	220.13 - 621-12	174.10 - 650	M8L Je-410671	2 SMS 795	257.9 - 150	SEKN 1203 AFTN
220.130 - 125	220.13 - 621-12	174.10 - 650	M8L Je-410671	2 SMS 795	257.9 - 150	SEKN 1203 AFTN
220.130 - 160	220.13 - 621-12	174.10 - 650	M8L Je-410671	2 SMS 795	257.9 - 150	SEKN 1203 AFTN
220.130 - 200	220.13 - 621-12	174.10 - 650	M8L Je-410671	2 SMS 795	257.9 - 150	SEKN 1203 AFTN

Weitere Durchmesser auf Anfrage

Planfräser

RG 45

257.1

Einstellwinkel 75°, wird in Rechts- (R) und Linksausführung (L) hergestellt

Schneidewinkel: Spanwinkel 2°
 Axialwinkel 7°
 Radialwinkel 0°

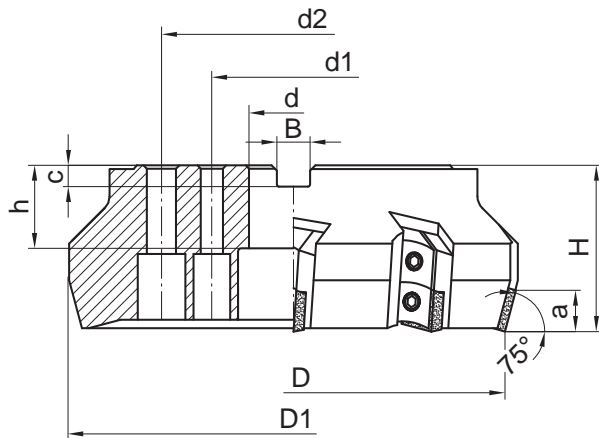

4

Besonderheit:
 Ungleichmäßige Teilung → verhindert Rattern

Face milling cutter

Bestell-Nr.	Durchmesser	€/ Stück	D	D1	d	d1	H	h	B	C	a	Z
6 657 1080	R257.1 - 080-10	332,20	80	90	27	-	50	22	12,4	7	9	6
1100	R257.1 - 100-10	516,70	100	110	32	-	50	25	14,4	8	9	8
1125	R257.1 - 125-10	561,20	125	135	40	-	63	29	16,4	9	9	8
1160	R257.1 - 160-10	690,60	160	170	40	66,7	63	29	16,4	9	9	10
1200	R257.1 - 200-10	872,80	200	210	60	101,6	63	40	25,7	14	9	12

Ersatzteile: (Preise siehe Ersatzteilpreislise auf Seite 98)	Auflageplatte	Keil	Keilschraube	Exzenter- schlüssel	Sechskant- schlüssel	Wendeplatte
R257.1-080-10	R 257.9 - 114	R 257.9 - 120	257.9 - 132	257.9 - 140	257.9 - 150	SPKN 1203 EDR
R257.1-100-10	R 257.9 - 114	R 257.9 - 120	257.9 - 132	257.9 - 140	257.9 - 150	SPKN 1203 EDR
R257.1-125-10	R 257.9 - 110	R 257.9 - 120	257.9 - 130	257.9 - 140	257.9 - 150	SPKN 1203 EDR
R257.1-160-10	R 257.9 - 110	R 257.9 - 120	257.9 - 130	257.9 - 140	257.9 - 150	SPKN 1203 EDR
R257.1-200-10	R 257.9 - 110	R 257.9 - 120	257.9 - 130	257.9 - 140	257.9 - 150	SPKN 1203 EDR





































































Weitere Durchmesser auf Anfrage

Ersatzteile:

RG 47

Klemmhalter & Messerköpfe

Spare parts:

Bestell-Nr.	Bezeichnung	€/ Stück	Bestell-Nr.	Bezeichnung	€/ Stück
6 600 0016	 M4 Je 410040	6,90	6 600 0183	 117.26 - 686	11,50
0017	 M6 x 0,75L Je 410790	10,40	0190	 123.26 - 622	17,10
0018	 M8L Je 410671	14,10	0198	 150.17 - 643	24,00
0021	 M10x45 Je 410724	5,60	0199	 150.17 - 644	24,00
0030	 P - 368.02	7,80	0201	 150.17 - 656	4,90
0100	 PTF 11	18,30	0211	 170.26 - 650.1	7,30
0101	 PTF 12	18,10	0215	 171.66 - 624	20,80
0102	 PTF 13	18,00	0217	 171.66 - 660	9,30
0105	 R 166.10.621.1	18,40	0218	 171.66 - 650	16,00
0106	 R 166.10.621.2	18,40	0219	 171.66 - 650.1	11,00
0107	 R 166.10.621.3	18,40	0228	 174.10 - 650	1,60
0108	 S - 2504	15,00	0242	 174.16 - 636	2,60
0109	 S - 2506	2,30	0245	 174.16 - 639	3,50
0110	 S - 4008	2,30	0250	 174.16 - 644	3,10
0116	 T 7	8,90	0251	 174.16 - 645	4,60
0117	 T 15	5,80	0254	 174.16 - 648	6,70
0118	 T 9	10,40	0266	 175.11 - 624	14,10
0119	 T 7 - F	13,35	0286	 220.13 - 621-12	14,10
0120	 T 9 - F	8,70	0290	 220.17 - 690	2,60
0121	 T 15 - F	15,60	0291	 220.17 - 691	3,20
0130	 2 SMS 795	0,80	0292	 220.17 - 692	2,90
0131	 3 SMS 795	1,20	0300	 R 257.9 - 110	25,00
0132	 4 SMS 795	2,00	0302	 R 257.9 - 114	24,00
0133	 5 SMS 795	2,80	0304	 R 257.9 - 120	8,60
0134	 6 SMS 795	3,40	0305	 257.9 - 130	5,00
0135	 8 SMS 795	4,80	0306	 257.9 - 132	5,00
0136	 10 SMS 795	6,20	0307	 257.9 - 140	24,80
0150	 110.26 - 640	6,30	0308	 257.9 - 150	7,90
0151	 110.26 - 641	6,30	0309	 GP-16-01	39,00
0160	 111.26 - 622	15,30	0310	 KK-090-10	24,00
0170	 117.16 - 630	7,60	0311	 KS-060.16	2,70
0171	 117.16 - 631	12,90	0313	 GSR-3.06	4,40
0180	 117.26 - 622	17,00	0314	 S-3509	13,30
0181	 117.26 - 650.1	5,00			
0182	 117.26 - 655	3,50			